

Ideas, Engineering and Manufacture

**AGOM**<sup>®</sup>

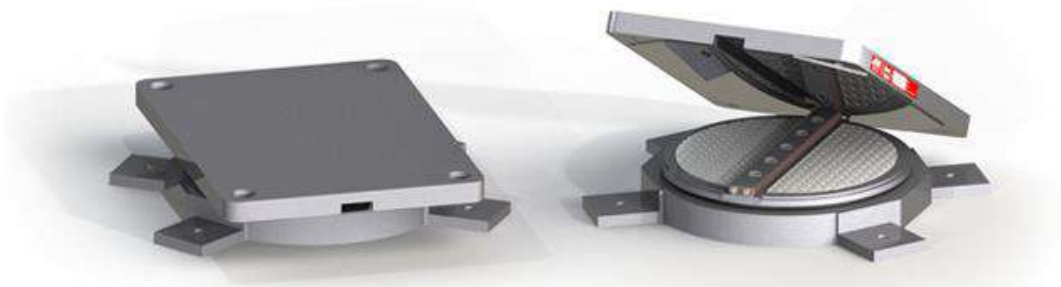

# AGOM V-Max

## Pot bearings

AGOM INTERNATIONAL SRL

Via Mesero, 12 – 20002 Ossona (MI) – Italy – [www.agom.it](http://www.agom.it)  
PH.: +39 02 9029111 – FAX: +39 02 9010201 – [agom@agom.it](mailto:agom@agom.it)

### AGOM International: Experience and Quality

Bridges are subjected to movements and rotation caused by traffic, temperature changes, earthquakes, shrinkage, prestressing, creep, etc. Bridge construction requires carefully designed and manufactured bearings, anti-seismic devices, shock absorbers and expansion joints to ensure that such forces are properly dealt with throughout the life of the structure.

Agom has over 50 years' experience in design and manufacturing bridge bearings, bridge expansion joints, anti-seismic devices and shock absorbers for bridge-building and construction industry. All products comply with the latest European standards and all main international standards.

The quality and durability of these products are ensured by:

- our team of skilled engineers, who can conceptualise and design the most appropriate engineering solutions
- qualified professionals, trained and continually updated in quality production techniques
- virgin raw materials that are quality assessed in our on-site testing laboratory
- ISO 9001:2015 quality standard accreditation
- strict quality control processes
- periodical external inspections by globally recognized bodies such as the TZUS of Prague and Certiquality:
- independent international inspection and certification authorities.



### General features of pot bearings

AGOM V-Max pot bearings are designed to carry combinations of vertical loads, horizontal loads, longitudinal and transversal movements and rotations and they are used in steel and concrete road and railway bridges.

A completely encased rubber pad is positioned in a steel pot. Under high pressure the pad behaves like a liquid. The elasticity of the rubber allows tilting movement (rotation) of the piston in the horizontal axis.

Depending on whether the bearing is fixed, guided sliding or a free sliding, V-Max bearings accommodate vertical loads and corresponding horizontal forces, as well as movements in longitudinal or transversal directions.

### Load Combinations

V-Max pot bearings can carry very high loads, over 100.000 kN.

The bearings are designed for combined maximum vertical and horizontal loads. The standard range of AGOM pot bearing is designed to have a horizontal load  $\leq 15\%$  of the maximum vertical load with a maximum rotation  $\pm 0.01$  rad (other load and rotation combinations are provided on request). To define the correct bearing, our engineers take into account the designed load effects, rotations, displacements and type of fixings.

### Pot bearing types

#### Fixed type V-Max AGPF

These bearings consist of 2 steel plates, the basement (“pot”) and the piston assembled with an elastomeric disc which is encapsulated and fitted with an anti-extrusion sealing device. Under load this encapsulated elastomeric disc acts in a similar manner to an incompressible confined fluid, enabling the pot and piston to rotate relative to each other. V-Max AGPF bearings enable rotation in any direction while at the same time the structure is constrained horizontally. The pot and piston feature fittings for securing the bearing to the bridge structure.



#### Free sliding V-Max AGPM

Similar in construction to the fixed bearings, in these multi-directional devices the piston is equipped with a virgin PTFE sheet in contact with an austenitic steel sheet welded to the sliding plate, thus enabling the bearing to slide in all directions.



#### Guided sliding type V-Max AGPL-AGPT

Guided sliding devices are identical in construction to free sliding bearings but are also equipped with one or more guides to limit the bearing’s movement to only one direction.

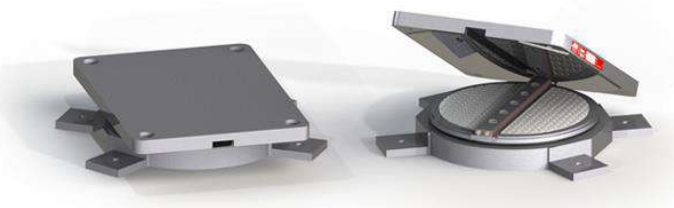

### V-Max bearings with special devices

AGOM V-Max bearings can be combined with special devices as:

- anti-lifting system
- hydraulic devices
- elastic devices

#### V-Max bearing combined with anti-lifting system

V-Max bearing can be equipped with anti-lifting tool to absorb the negative tensile vertical forces. The anti-lifting tools can be applied to all the V-Max bearings (fixed, guided and free sliding) with different systems depending on the bearing type and tensile load value. It is possible to cover a very wide range of tensile loads by suitable design of anti-lifting tools.



#### V-Max bearing combined with hydraulic devices

The hydraulic devices that can be combined with AGOM V-Max bearings are of two types:

- Shock Transmitter (ST). It allows the slow movement (velocity  $< 0.1$  mm/sec) due to service conditions (thermal, shrinkage, fluage) while it blocks in case of fast motion (seismic etc..) and transmits the horizontal load along the device axis.
- Viscous Damper (VD). It allows the slow movement (velocity  $< 0.1$  mm/sec) due to service conditions (thermal, shrinkage, fluage) while it reacts in case of fast motion (seismic etc..); it reaches the design load and allows the motion dissipating energy. It works as a viscous damper with very high damping capacity (higher than 50% of the critical damping); the response cycles in term of force-displacement and force-velocity can be adjusted according to the structural designer requirements.

AGOM V-Max bearings combined with hydraulic devices are thus available with different configurations:

- longitudinal guided bearings with hydraulic Shock Transmitter AGPL ST; it allows rotations of a spherical hinge and the horizontal displacement in the longitudinal direction for slow motion; it carries the vertical load, the horizontal load along the transversal direction and the longitudinal one due to dynamic actions;
- free sliding bearing with hydraulic Shock Transmitter AGPM ST; it allows rotations of a spherical hinge and the horizontal displacement along each direction of the horizontal plane for slow motions; it carries the vertical load and the longitudinal one due to dynamic actions;
- longitudinal guided bearings with hydraulic Viscous Damper AGPL VD; it allows rotations of a spherical hinge and the horizontal displacement in the longitudinal direction for slow motion; it carries the vertical load, the horizontal load along the transversal direction and the longitudinal one due to dynamic actions with very high energy dissipation;
- free sliding bearing with hydraulic Viscous Damper AGPM VD; it allows rotations of a spherical hinge and the horizontal displacement along each direction of the horizontal plane for slow motions; it carries the vertical load and the longitudinal horizontal one due to dynamic actions with very high energy dissipation.

### V-Max bearing with horizontal elastic stiffness

AGOM V-Max bearing can be equipped with elastic tools in order to provide an elastic horizontal response. The elastic response in the horizontal direction (one or two directions) can be useful for particular applications (example bridge with very high curvature to minimize the parasite effects due to the bearing guide alignments or to equalize the horizontal forces between bearings).



### Materials

#### Rubber compound

The elastomer material used for the elastomeric pad is natural rubber or chloroprene rubber in accordance with ISO 6446.

Property	Test method	Requirement
Tensile strength	ISO 37 type 2	$\geq 15,5$ MPa
Elongation at break	ISO 37 type 2	$\geq 450\%$
Compression Set 22 h; 70 °C	ISO 815	$\leq 30\%$
Hardness	ISO 48	$50 \pm 5$ IHRD

#### Structural Steel

The pot plate, the piston and, if present, the sliding plate are manufactured from steel material in accordance with EN 10025 standard.

#### Austenitic steel sheet

The austenitic steel used for sliding surfaces is X5CrNiMo17-12-2 in accordance with EN 10088-2 1.4401 with a minimum thickness of 1.5 mm.

The roughness is  $R_{y5i} \leq 1$   $\mu\text{m}$ . The hardness is  $\geq 150$  HV1 and  $\leq 220$  HV.

#### PTFE

AGOM uses only virgin PTFE without regenerated or filler materials.

The minimum thickness of recessed PTFE is 4.5 mm and varies according with the bearings size and standard. Friction force is calculated according with the current Standard Code.

Characteristic	Test method	Requirement
Tensile strength	ISO 527-1/3	$\geq 29$ MPa
Elongation at break	ISO 527-1/3	$\geq 300\%$
Hardness	EN ISO 2039-1	H132/60=23 to 33 MPa

### Bearing fixing

Usually, all the V-Max bearings are equipped with suitable anchor bars for anchoring purpose to lower and upper structure.

In case of pre-cast concrete beam, the bearings can be provided with upper pin and top subsidiary plate; in case of steel beams the bearings shall be provided with upper pin and/or connecting bolts.

To adjust the angle of inclination of the superstructure, the pot bearing's top plate can be manufactured tapered, or a wedge plate can be fixed at the top of the bearing.

In case of horizontal loads  $< 20\%$  of the simultaneous vertical load, if there is sufficient friction between the bearing and the sub or superstructure, the anchor bolts can be left out and the bearing can be connected to the structure by means of cementitious or epoxy resin (if the local code allow it).

To improve the V-Max bearings replacement with minimal up-lift of the structure, suitable steel counterplates can be provided.





### V-Max bearings accessories

#### Movement gauge

The movement indicator allows monitoring the sliding plate displacements by using a reference arrow fixed to the bearing base and a graduate indicator moving with the sliding plate. The movement gauge allows to check the initial presetting of the bearing (if required) and to verify the bearing movement during the future inspections.

#### Dust protection

The (removable) dust protection around the sliding plate ensures the cleaning of the sliding surfaces to minimize the friction during sliding movements and guarantees the durability of the PTFE sliding material.

### Comprehensive Labelling

All the V-Max bearings are provided with a metal label detailing the proprieties of the bearings:

- bearing type
- maximum vertical and horizontal loads
- movement capacity
- design rotation
- order number
- date of manufacture
- CE Mark (if applicable)



The top face of the bearing gives information on the type of the bearing, the direction of the axis of the bridge, the presetting (if any), the position.

### Corrosion protection

Steel components exposed to the elements are protected against corrosion. AGOM adapts the corrosion protection in accordance with the aggressiveness of the environment in which the bearings are to be installed and to each customer's requirements.

The standard corrosion protection according EN 1337-9 is as follows:

- sandblasting grade SA2.5
- two components high thickness epoxy zinc paint (min 250 µm).

The high resistant corrosion protection (environment class CX EN12944) is as follow:

- sandblasting de grade SA2.5
- zinc rich epoxy primer, with minimum thickness of dry film 75 µm
- epoxy mastic intermediate, with minimum thickness of dry film 175 µm
- polyurethane topcoat, with minimum thickness of dry film 75 µm.

### Quality and International Standards

AGOM V-Max bearings are designed and manufactured in accordance with the requirements of the European standard EN 1337-3 and are qualified with the CE mark.

AGOM can also provide pot bearings in accordance with other standards of a wide range of international standards (American AASHTO, British BS 5400, Canadian CSA,...). The compound used in the molding process can be polychloroprene (neoprene) or natural rubber depending on the required specifications. Every single steel component is mechanically worked and assembled by fully qualified and trained workers inside the AGOM factory under strict ISO 9001:2015 accredited quality control standards.



## Qualification, approval tests and certifications

All the qualification and approval tests are performed by independent and worldwide recognized laboratories to assure that the V-Max bearings performances comply with the project and with international standard requirements.



**CE  
MARK**



**FRICION  
TESTS**

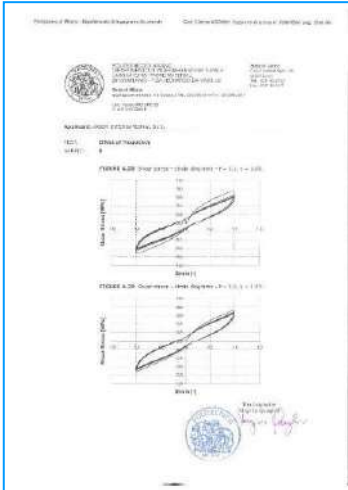

**DYNAMIC  
FATIGUE  
TESTS**



### Handling and storage

Care should be taken in storage to prevent contamination and damage to the working surfaces. AGOM bearings should be stored in a controlled environment where they are protected from contamination, misuse and excessive moisture.



Robust transportation devices are fitted to all bearings to ensure that the movable components are maintained in their correct relative positions before and during installation. These temporary fixing devices are normally finished in red paint and shall be removed after installation.

Unless special devices have been specified, they should not be used for slinging or suspending the bearings beneath beams.

Due to unpredictable conditions, which may occur during transportation or handling on site, the alignment and pre-setting (if applicable) of the assembled bearing should be checked against the drawing.

Do not try to rectify any discrepancies on site.

Bearing too heavy to be lifted by hand should be properly slung using lifting equipment.

### Pre-setting

If bearing is required to be pre-set, e.g. where once only large movements may occur during stressing operations, this should be specified as a requirement and should only be carried out in AGOM prior to despatch. Do not attempt this operation on site.



### Installation

Under control of the Engineer who designed the bridge, bearings must be installed by expert workers, with precision to meet the bridge and bearing design criteria.

Inappropriate handling, storage and installation will have an adverse effect on the bearing life, usually estimated in more than 50 years providing right maintenance.

AGOM structural bearings are manufactured to close tolerances by skilled technicians working in clean conditions. To obtain the requisite performance from bearings it is imperative that they are properly handled at the work site and installed with the same care as when they were assembled in the factory.

AGOM bearings are clearly identified and marked on the top plate (if present) to ensure correct installation. The typeface on the cover or sliding plate gives information on the type, size and number of the bearing. Moreover, arrows indicate the movement axis and the pre-setting direction (if applicable).

For all the detailed information about installation procedure and maintenance, see AGOM manual “V.Max Installation & maintenance” that can be download from AGOM web site [www.agom.it](http://www.agom.it).

### Maintenance

The service life of a pot bearing is usually estimated in more than 50 years.

The most important thing to assure such a long lifetime is a correct and careful maintenance of the bearing, that is usually installed in a severe environment.

The requested bearing inspection and maintenance program that could be adapted and improved by the Bridge Designer to the specific service conditions of the bridge is fully described in the “V-Max - Inspection and warranty manual” that can be download from AGOM web site [www.agom.it](http://www.agom.it).



### Guidelines for the design of a structure with AGOM E-Link bearings

In this section a simple guideline for the design of a structure equipped with AGOM bearing is presented.

The design procedure is summarized in the following steps:

1. Selection of the structure static link scheme (fixed and movable bearings).
2. Calculation of the loads (vertical and horizontal) on the bearings according to the fixing scheme.
3. Calculation of the bearing rotations and movements.
4. Insertion of all the bearing design data into the bearing design table (example table B.1 of the EN1337-1 code attached at the end of the document).
5. Using the bearing drawings provided by AGOM, design of the interface parts between structure and bearings as: bearing lower plinth with adequate position for installing the bearing anchor bars (if required), level of the plinth to fit the vertical space between lower and upper structure, the upper structure interface where the bearing upper plate will be positioned.
6. If necessary, design of the slope compensator to be placed between the bearing and upper structure in order to adjust the permanent slope (longitudinal and transverse slopes of a bridge deck). The deck's slope must be always compensated in order to keep the sliding surface in the horizontal plane (normally the slope is compensated above the bearing between its sliding plate and the upper structure). In any case the whole bearing cannot be installed inclined.

Here below we summarize the main features of the different bearing types in order to direct the choice towards the most convenient type.

	V-MAX pot bearing	R-MAX spherical bearing	E-LINK rubber bearings
Vertical load	High	High	Medium
Horizontal displacement	No Limits	No Limits	Medium
Rotation	Medium	High	Low-Medium
Dimension	Small-Medium	Small-Medium	High

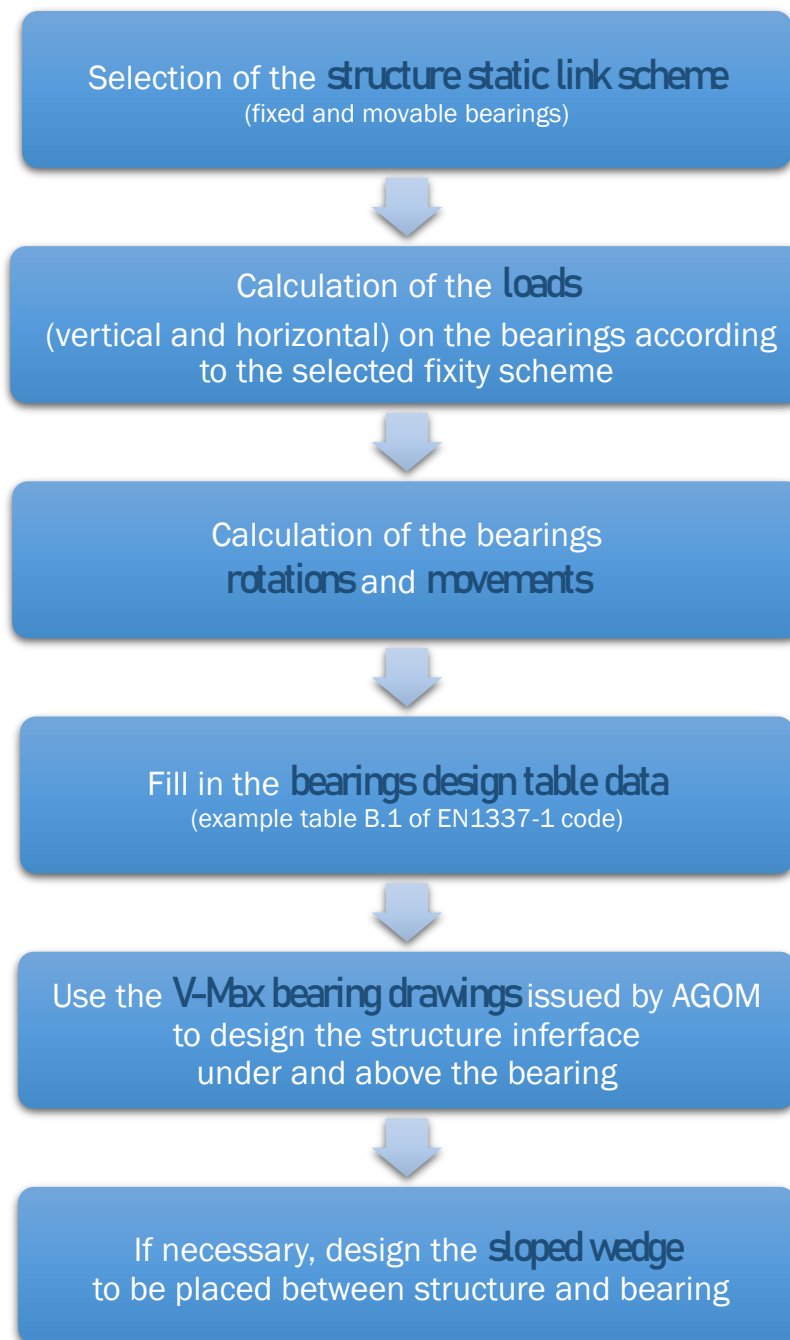

### Advantages of using AGOM V-Max pot bearings

AGOM pot bearings fulfil the following requirements.

- a. Transmit the vertical loads due to permanent and accidental effects; it is possible to cover a wide range of loads about up from 500 to 100000 kN.
- b. Transmit the horizontal loads within practise no limitation of the design load.
- c. Allow rotation as per a spherical hinge; standard design is for rotation  $\pm 0.01$  rad or  $\pm 0.02$  rad.
- d. No limitation for of horizontal displacement.
- e. Suitable for all structures steel and concrete bridges and buildings.
- f. High durability and no maintenance.

### Restoring moment factors

The restoring moment factors for AGOM V-Max bearings (according to EN1337-5 code section 6.1.3) are:

$$F_0 = 0.0072$$

$$F_1 = 0.8227$$

$$F_2 = 0.3949$$



### AGOM V-Max design parameters

Normally the required input parameters that the structural Designer must provide to AGOM Engineers for device design and constructions are the ones shown for example by the table B.1 of EN1337-1 code (see following pages):

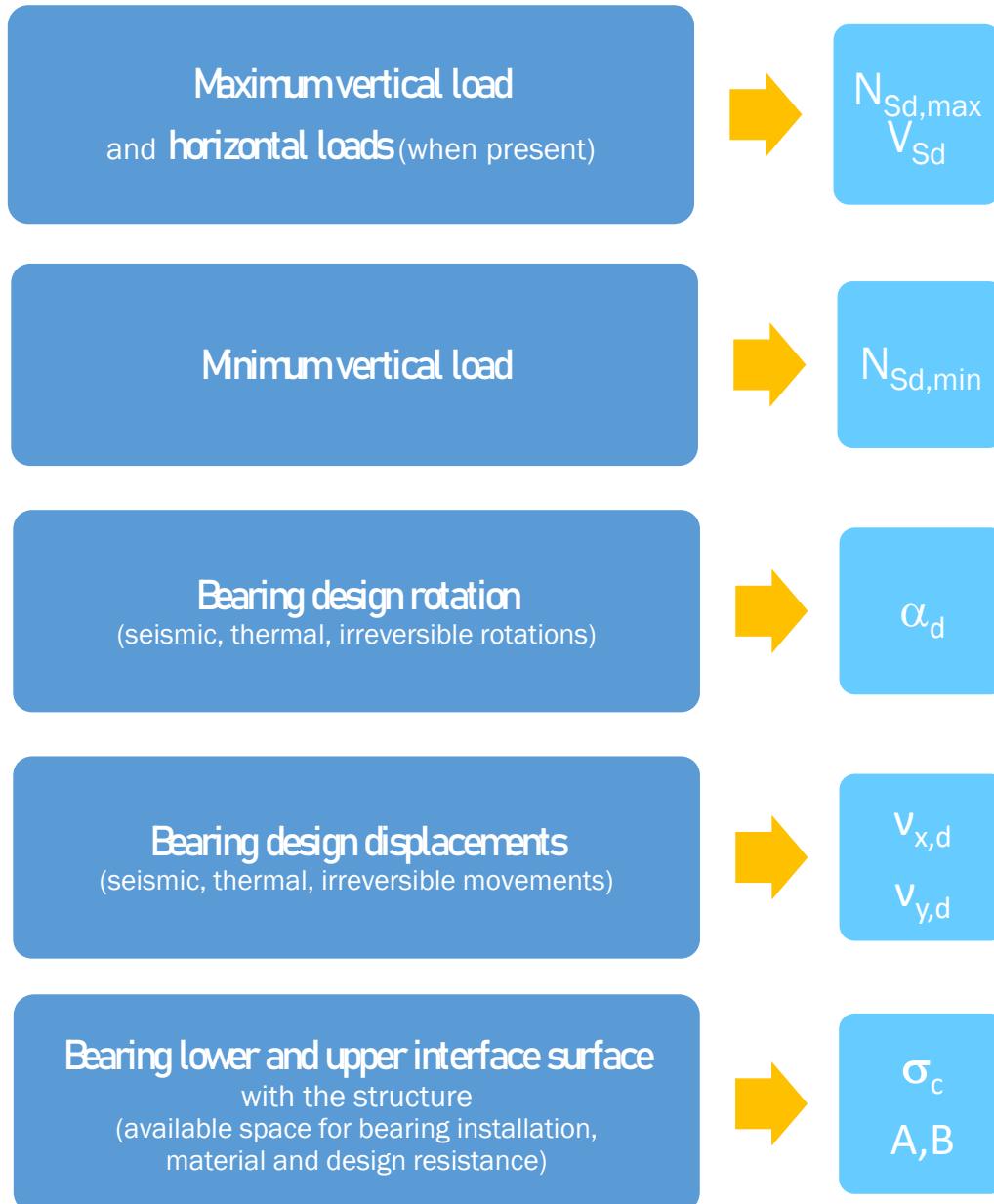

### Bearing design table according to EN1337-1 code

The purpose of this bridge bearing schedule is to list the information normally required for the design of the bearings for a particular structure. This information should ensure that bearings are designed and manufactured so that, under the influence of all possible actions, unfavourable effects of the bearing on the structure are avoided. A drawing should accompany the schedule showing the layout of the bearings with identification marks, including a typical cross section of the bridge and particular of any special locating requirements. Bearing function should be indicated on the drawing by appropriate symbols.

Every item listed in the “bearing design table” should be considered, but some may not be applicable to a particular bearing. Only relevant information should be given and when an item in the schedule is not applicable this should be stated. Additional information should be added when special conditions exist.

Here above you can find a short explanation of each item listed in the “bearing design table”.

BEARING IDENTIFICATION MARK	Bearing with different function or load carrying requirements should be distinguished by a unique reference mark.
NUMBER OFF	The required number for each item.
SEATING MATERIAL	The materials on which each outer bearing plate bears should be stated as it may affect the design and finish of these plates.
AVERAGE DESIGN CONTACT PRESSURE	The pressure of the effective contact area.
DESIGN LOAD AFFECTS	The structure designer should give the worst individual values of the design load effects in the schedule. The most adverse combination of these values is usually sufficient for a satisfactory design of bearing. Only in special cases would greater economy be achieved by considering the actual coexistent values of load effects, in which case these should be given in detail.
DISPLACEMENT	<p>Displacement of the structure at a bearing should be determined and factored. Allowance should be made for any movement of the supporting structures.</p> <p>Transverse and longitudinal movements are normally in a direction perpendicular and parallel to the longitudinal axis of a bridge span, respectively. Where there is any likelihood of ambiguity directions of movement should be clearly indicated on the accompanying drawing.</p>

## AGOM V-Max – Pot bearings

---

ROTATION	The irreversible and reversible rotations at the serviceability limit state (SLS), which the bearing is required to accommodate, should be given in radians.
MAXIMUM BEARING DIMENSIONS	The maximum sizes of the bearing that can be accommodated should be stated.
TOLERABLE MOVEMENT OF BEARING UNDER TRANSIENT LOADS	The movement that can be tolerated at the bearing under transient loads, in directions in which the bearing is meant to provide restraint.
ALLOWABLE RESISTANCE TO TRASLATION UNDER SLS [kN] ( <i>if relevant</i> )	In the design of the structure, reaction to displacement movements may be of significance, in which case the acceptable horizontal force generated by the bearing should be given for the serviceability limit state (SLS). The values to be given are those for slowly applied movements at normal temperatures (any necessary extra allowance for low temperatures and rapidly applied movements should be made by the designer of the structure).
ALLOWABLE RESISTANCE TO ROTATION UNDER SLS [kN*m] ( <i>if relevant</i> )	In the design of the structure, reaction to rotation may be of significance in which case the acceptable moment of reaction generated by the bearing, when subjected to the critical design load effects, should be given for the serviceability design state.
TYPE OF FIXING REQUIRED	Various means of fixing the bearing to the superstructure and substructure are available, appropriate to different type of bearing. Particular requirements, such as friction, bolts, dowels, keys or other devices, should be stated.

# AGOM V-Max – Pot bearings

## Bearing Design Table

Reference:.....

Date:.....

Bridge Name: .....

Table: ..... of .....

BEARING IDENTIFICATION MARK							
NUMBER OFF							
SEATING MATERIAL (e.g. cement, mortar, epoxy mortar, in situ concrete, precast concrete, steel, timber)	Upper surface						
	Lower surface						
AVERAGE DESIGN CONTACT PRESSURE [N/mm <sup>2</sup> ]	Upper face	SLS					
		ULS					
	Lower face	SLS					
		ULS					
DESIGN LOAD EFFECTS [kN]	ULS	vertical	Max				
			Perm.				
			Min.				
		Transverse					
	Longitudinal						
	SLS	Vertical					
		Transverse					
		Longitudinal					
DISPLACEMENT [mm]	ULS	Transverse					
		Longitudinal					
	SLS	Transverse					
		Longitudinal					
ROTATION [mrad]	ULS	Transverse					
		Longitudinal					
MAXIMUM BEARING DIMENSIONS [mm]	Transverse						
	Longitudinal						
	Overall Height						
TOLERABLE MOVEMENT OF BEARING UNDER TRANSIENT LOADS [mm] <i>(if relevant)</i>	Vertical						
	Transverse						
	Longitudinal						
ALLOWABLE RESISTANCE TO TRASLATION UNDER SLS [kN] <i>(if relevant)</i>	Transverse						
	Longitudinal						
ALLOWABLE RESISTANCE TO ROTATION UNDER SLS [kN·m] <i>(if relevant)</i>	Transverse						
	Longitudinal						
TYPE OF FIXING REQUIRED	Upper face						
	Lower face						

### AGOM V-Max standard range

AGOM V-Max bearings can cover a very wide range of loads and displacements, they can be designed according to many international standards (European EN 1337, American AASHTO LRFD, British BS5400, etc..).

The bearings dimensions shown in the following tables have been designed according to European codes EN 1337 with the following criteria:

- EN 1337 part 1 and 5 and relevant European codes for load and displacements calculation. Note that the bearing design loads (shown in the tables) are ultimate limit state loads (ULS);
- EN 1337 part 2 for sliding surfaces;
- Standard rotation  $\pm 0.01$  rad;
- Total displacement 100 mm ( $\pm 50$  mm);
- Horizontal load equal to 15% of the maximum vertical one;
- Concrete stress calculated according to EC2 - EN1992-1-1 standard with concrete class C30/37, levelling mortar with minimum compression resistance  $f_c = 50$  N/mm<sup>2</sup> and plinth size at least 100 mm greater than bearing plate.

In any case the dimension can be adjusted to fit the available space on the structure and/or to verify the contact stress on the interface surface (example different concrete class respect to the one used for the bearing standard design, etc..).

**Since the bearings checks depends on the combination of multiple inputs (load, displacement and rotation), AGOM engineers can assist the structural designer for design optimisation.**

# AGOM V-Max – Pot bearings

## Agom V-Max Fixed Bearings

Fixed bearing type AGPF (Vertical load - Horizontal longitudinal load - Horizontal transversal load).

For example AGPF 500-75-75 means: Vertical load  $N_{Rd} = 500$  kN, Horizontal longitudinal load  $V_{x,Rd} = 75$  kN, Horizontal transversal load  $V_{y,Rd} = 75$  kN.

Bearing type	Bearing Dimensions						Weight
	$\varnothing B$	H	nZ	$\varnothing Z$	LZ	A	W
	[mm]	[mm]		[mm]	[mm]	[mm]	[kg]
V-Max AGPF 500-75-75	210	56	2	30	122	290	23
V-Max AGPF 1000-150-150	220	56	2	30	122	300	24
V-Max AGPF 1500-225-225	260	60	2	40	140	360	38
V-Max AGPF 2000-300-300	300	62	2	40	140	400	45
V-Max AGPF 2500-375-375	340	69	2	50	188	460	74
V-Max AGPF 3000-450-450	366	69	4	40	140	466	99
V-Max AGPF 4000-600-600	426	81	4	40	140	526	127
V-Max AGPF 5000-750-750	476	85	4	50	188	596	197
V-Max AGPF 6000-900-900	516	88	4	50	188	636	217
V-Max AGPF 7000-1050-1050	560	96	4	60	235	700	300
V-Max AGPF 8000-1200-1200	600	95	4	60	235	740	318
V-Max AGPF 9000-1350-1350	640	104	4	60	235	780	362
V-Max AGPF 10000-1500-1500	676	113	4	60	235	816	409
V-Max AGPF 12000-1800-1800	736	111	4	70	282	896	537
V-Max AGPF 14000-2100-2100	810	128	4	80	330	990	788
V-Max AGPF 16000-2400-2400	850	142	4	80	330	1030	885
V-Max AGPF 18000-2700-2700	900	142	4	80	330	1080	940
V-Max AGPF 20000-3000-3000	970	151	4	90	375	1170	1244
V-Max AGPF 22500-3375-3375	1020	159	4	90	375	1220	1361
V-Max AGPF 25000-3750-3750	1080	167	4	100	420	1300	1705
V-Max AGPF 27500-4125-4125	1140	185	4	100	420	1360	1957
V-Max AGPF 30000-4500-4500	1180	174	6	90	375	1380	2269
V-Max AGPF 35000-5250-5250	1280	191	6	100	420	1500	3033
V-Max AGPF 40000-6000-6000	1370	199	6	100	420	1590	3318
V-Max AGPF 45000-6750-6750	1470	217	8	100	420	1690	4400
V-Max AGPF 50000-7500-7500	1550	225	8	100	420	1770	4762

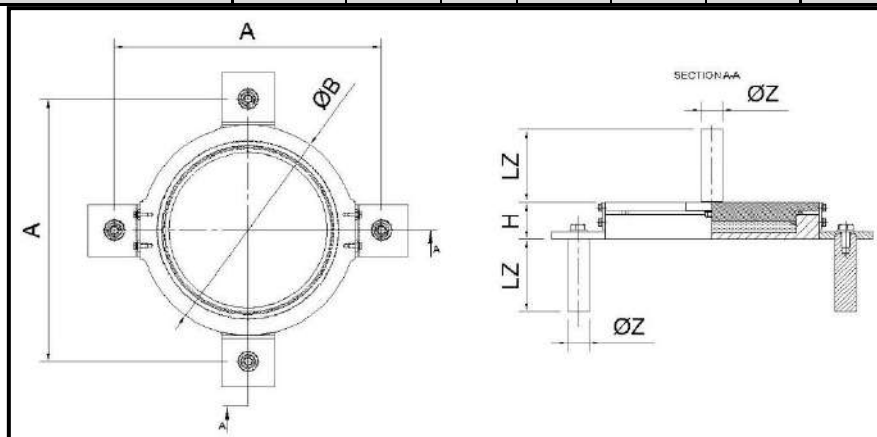

# AGOM V-Max – Pot bearings

## Agom V-Max Guided Bearings

Guided bearing type AGPL (Vertical load / Horizontal longitudinal movement - Horizontal transversal load).

For example: AGPL 500/100-75 means: Vertical load  $N_{Rd} = 500$  kN, horizontal longitudinal movement  $v_{x,d} = 100 (\pm 50)$  mm, horizontal transversal load  $V_{y,Rd} = 75$  kN. In case of AGPT bearings, the movement is along transversal axis and the horizontal load along the longitudinal one.

Bearing type	Bearing Dimensions													Weight W
	ØB	H	nZ	ØZ	LZ	A	C	D	nU	ØU	LU	E	F	
	[mm]	[mm]		[mm]	[mm]	[mm]	[mm]	[mm]		[mm]	[mm]	[mm]	[mm]	
V-Max AGPL 500/100-75	210	79	2	30	122	290	210	340	4	30	122	150	280	34
V-Max AGPL 1000/100-150	220	79	2	30	122	300	220	340	4	30	122	160	280	36
V-Max AGPL 1500/100-225	260	82	2	40	140	360	260	370	4	30	122	200	310	50
V-Max AGPL 2000/100-300	300	83	2	40	140	400	300	390	4	40	140	220	310	60
V-Max AGPL 2500/100-375	340	90	2	50	188	460	340	420	4	40	140	260	340	87
V-Max AGPL 3000/100-450	366	95	4	40	140	466	366	440	4	40	140	286	360	109
V-Max AGPL 4000/100-600	426	107	4	40	140	526	380	510	4	40	140	300	430	145
V-Max AGPL 5000/100-750	476	111	4	50	188	596	430	550	4	50	188	330	450	206
V-Max AGPL 6000/100-900	516	119	4	50	188	636	470	590	4	50	188	370	490	244
V-Max AGPL 7000/100-1050	560	127	4	60	235	700	510	600	4	60	235	390	480	316
V-Max AGPL 8000/100-1200	600	128	4	60	235	740	550	630	4	60	235	430	510	348
V-Max AGPL 9000/100-1350	640	130	4	60	235	780	580	680	4	60	235	460	560	390
V-Max AGPL 10000/100-1500	676	140	4	60	235	816	600	720	4	60	235	480	600	444
V-Max AGPL 12000/100-1800	736	147	4	70	282	896	680	770	4	70	282	540	630	598
V-Max AGPL 14000/100-2100	810	171	4	80	330	990	730	830	4	80	330	570	670	838
V-Max AGPL 16000/100-2400	850	174	4	80	330	1030	780	880	4	80	330	620	720	933
V-Max AGPL 18000/100-2700	900	184	4	80	330	1080	800	910	4	80	330	640	750	1040
V-Max AGPL 20000/100-3000	970	201	4	90	375	1170	850	970	4	90	375	670	790	1343
V-Max AGPL 22500/100-3375	1020	199	4	90	375	1220	890	1020	4	90	375	710	840	1429
V-Max AGPL 25000/100-3750	1080	208	4	100	420	1300	940	1080	4	100	420	740	880	1753
V-Max AGPL 27500/100-4125	1140	236	4	100	420	1360	980	1140	4	100	420	780	940	2078
V-Max AGPL 30000/100-4500	1180	234	6	90	375	1380	1100	1220	8	80	375	940	1060	2412
V-Max AGPL 35000/100-5250	1280	249	6	100	420	1500	1170	1320	8	90	420	990	1140	3120
V-Max AGPL 40000/100-6000	1370	260	6	100	420	1590	1260	1370	8	90	420	1080	1190	3516
V-Max AGPL 45000/100-6750	1470	284	8	100	420	1690	1340	1470	8	100	420	1140	1270	4325
V-Max AGPL 50000/100-7500	1550	294	8	100	420	1770	1410	1550	8	100	420	1210	1350	4843

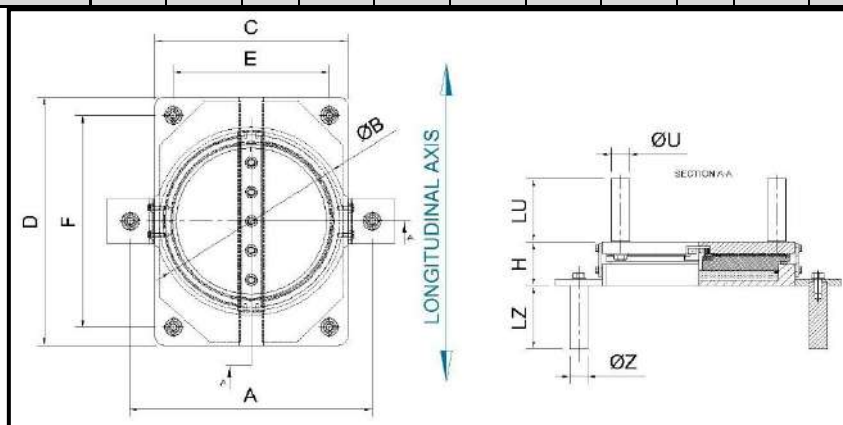

# AGOM V-Max – Pot bearings

## Agom V-Max Free Sliding Bearings

Free sliding bearing type AGPM (Vertical load / Horizontal longitudinal movement / Horizontal transversal movement).

For example: AGPM 500/100/20 means: Vertical load  $N_{Rd} = 500$  kN, Horizontal longitudinal movement  $v_{x,d} = 100 (\pm 50)$  mm , Horizontal transversal movement  $v_{y,d} = 20 (\pm 10)$  mm.

Bearing type	Bearing Dimensions													Weight
	$\varnothing B$	H	nZ	$\varnothing Z$	LZ	A	C	D	nU	$\varnothing U$	LU	E	F	W
	[mm]	[mm]		[mm]	[mm]	[mm]	[mm]	[mm]		[mm]	[mm]	[mm]	[mm]	[kg]
V-Max AGPM 500/100/20	210	64	2	30	122	290	210	340	4	30	122	150	280	28
V-Max AGPM 1000/100/20	220	64	2	30	122	300	220	340	4	30	122	160	280	30
V-Max AGPM 1500/100/20	234	68	2	30	122	314	234	350	4	30	122	174	290	33
V-Max AGPM 2000/100/20	270	68	2	30	122	350	270	360	4	30	122	210	300	39
V-Max AGPM 2500/100/20	310	77	2	30	122	390	310	380	4	30	122	250	320	53
V-Max AGPM 3000/100/20	330	77	2	30	122	410	330	400	4	30	122	270	340	58
V-Max AGPM 4000/100/20	390	82	2	30	122	470	390	450	4	30	122	330	390	80
V-Max AGPM 5000/100/20	434	95	2	30	122	514	434	490	4	30	122	374	430	112
V-Max AGPM 6000/100/20	470	94	2	40	140	570	470	520	4	30	122	410	460	131
V-Max AGPM 7000/100/20	506	99	2	40	140	606	506	550	4	30	122	446	490	155
V-Max AGPM 8000/100/20	540	103	2	40	140	640	540	580	4	30	122	480	520	177
V-Max AGPM 9000/100/20	580	113	2	40	140	680	540	610	4	30	122	480	550	214
V-Max AGPM 10000/100/20	614	117	2	40	140	714	570	640	4	30	122	510	580	245
V-Max AGPM 12000/100/20	670	117	2	50	188	790	620	690	4	40	140	540	610	292
V-Max AGPM 14000/100/20	730	131	2	50	188	850	680	740	4	40	140	600	660	385
V-Max AGPM 16000/100/20	776	131	2	50	188	896	720	780	4	40	140	640	700	424
V-Max AGPM 18000/100/20	826	143	4	40	140	926	760	820	4	40	140	680	740	529
V-Max AGPM 20000/100/20	874	147	4	40	140	974	800	860	4	40	140	720	780	596
V-Max AGPM 22500/100/20	920	166	4	50	188	1040	840	900	4	50	188	740	800	781
V-Max AGPM 25000/100/20	980	165	4	50	188	1100	890	950	4	50	188	790	850	855
V-Max AGPM 27500/100/20	1036	174	4	50	188	1156	930	990	4	50	188	830	890	988
V-Max AGPM 30000/100/20	1074	175	4	50	188	1194	970	1020	4	50	188	870	920	1058
V-Max AGPM 35000/100/20	1170	196	4	60	235	1310	1050	1100	4	60	235	930	980	1418
V-Max AGPM 40000/100/20	1250	205	4	60	235	1390	1120	1170	4	60	235	1000	1050	1660
V-Max AGPM 45000/100/20	1330	215	4	60	235	1470	1180	1230	4	60	235	1060	1110	1952
V-Max AGPM 50000/100/20	1400	224	4	60	235	1540	1240	1290	4	60	235	1120	1170	2223

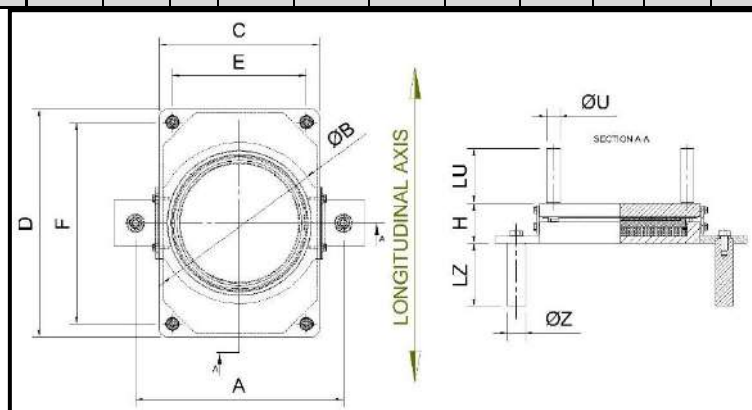



*MORE THAN 50 YEARS EXPERIENCE DESIGNING AND MANUFACTURING DEVICES FOR CONSTRUCTION, OFFSHORE AND INDUSTRIAL MARKETS*



### Expansion joints

- Elastomeric joints
- Joints for high movements
- Finger joints
- Buried joints
- Railway joints



### Bridge bearings

- Elastomeric Bridge bearings
- Pot bearings
- Spherical bearings
- Incremental launching bearings
- Horizontal load bearings
- Special bearings



### Seismic Protection

- Seismic Isolators
- High damping rubber bearings
- Lead core rubber bearings
- Multilayer rubber bearings
- Shock transmitters
- Viscous dampers
- Rubber dampers

### Services

- Design
- Consulting
- On site assistance
- Installations
- Tests
- Inspection

