



SMA *Aries*

REDIRECTIVE CRASH CUSHION



SMA Lite - Type Aries



80 Parallel



110 Parallel



80 Wide



110Wide

Shorter means safer

Shorter means safer

SMA Aries is the crash cushion with the shortest dimensions. This important characteristic reduces the probability of an impact onto a fixed obstacle.

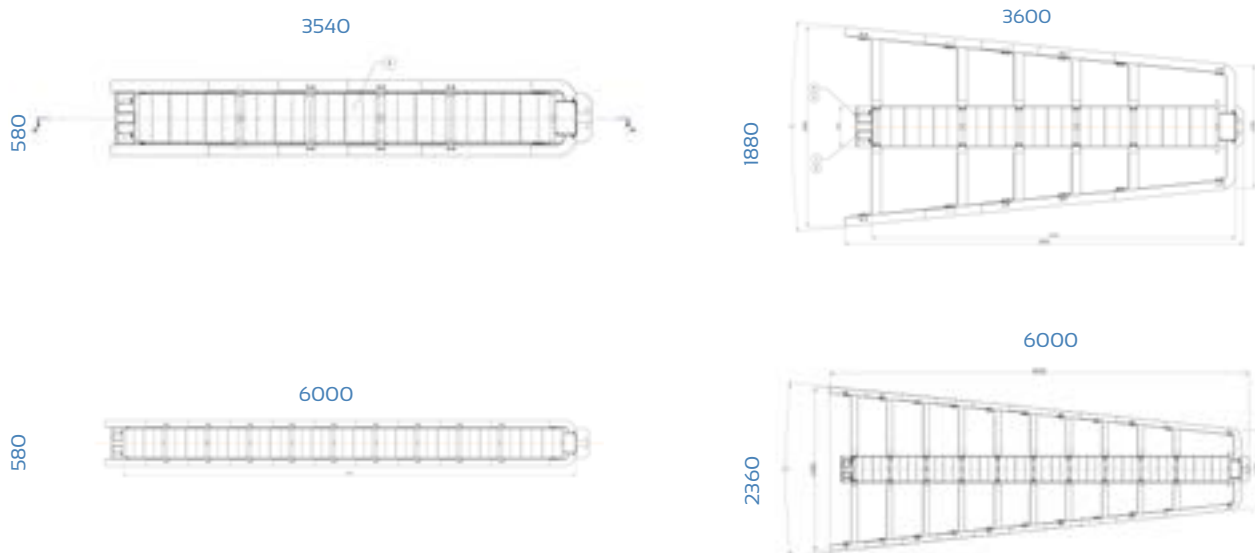

AVAILABLE MODELS

Parallel	SMA Aries - 80 P D4935	SMA Aries- 110 P D4911
Length	3540 mm	6000 mm
Width	580 mm	580 mm
Height	600 mm	600 mm

Wide	SMA Aries - 80 W D5091	SMA Aries- 110 W D4951
Length	3600 mm	6000 mm
Width	1880 mm	2360 mm
Height	600 mm	600 mm

EN 1317 Certified

The base structure (1) is completely made of electro-welded steel and consists of a rail (2) for the sliding of the sliding bar (3) and of the retaining panels (4) which permit the crush of the crashboxes (5). The bumper (6) is the frontal panel which permits the connection of the double beam sliding side panels (7), which slide back in a telescopic way during the impact, while the additional panels (8) give the trapezoidal shape to the crash cushion and permit the vehicle energy absorption in case of lateral impact.

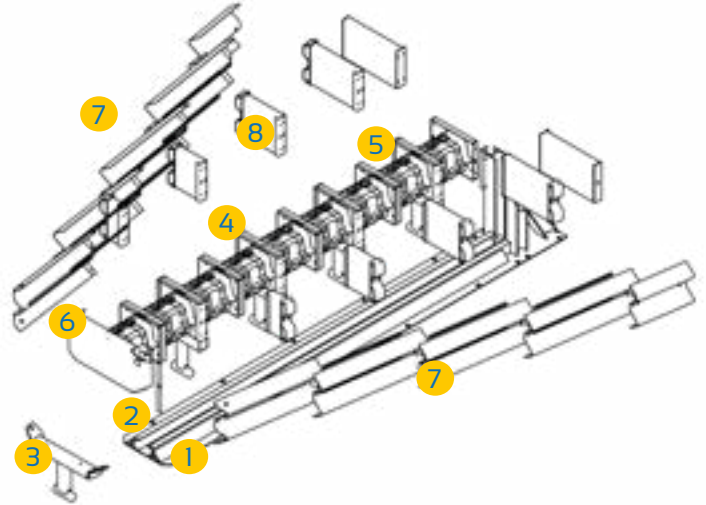

CE Certified

SMA Aries is a CE certified product and has successfully passed the crash tests according to the EN 1317-3



Crash Test TC 1.3.110



Crash Test TC 4.3.110

Installation

SMA Aries offers various installation opportunities depending on the Clients requests. The installation procedure is very fast and easy. As a result you save time and resource.

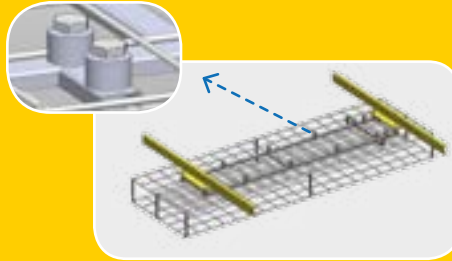

Installation with bushes

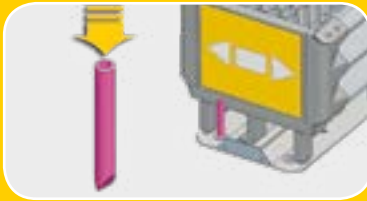

Installation with chemical anchors on concrete



Precasted concrete basement

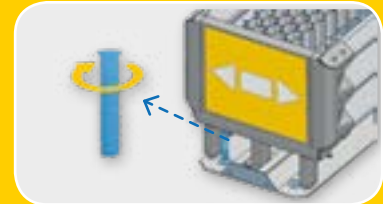

Installation with chemical anchors on asphalt

Repair

SMA Aries is totally repairable. After the impact, it is possible to replace the damaged components and completely reuse the rest of the system.

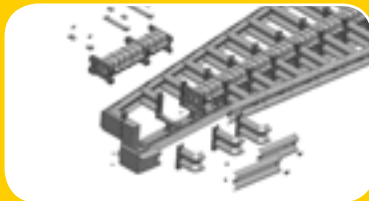

Crashbox repair



Side panels repair



SOLUTIONS DESIGNED TO SAVE LIVES

SMA Road Safety

Address: Via Dante Giacosa – Zona Industriale A.S.I. Sud
81025 Marcianise (CE) - Italy

Tel.: +39 0823 821560

info@smaroadsafety.com

www.smaroadsafety.com

